



BUENAVISTA WINDOWS

"A BETTER VIEW"

VINYL REPLACEMENT SERIES

3/4" OVERALL DUAL PANE

LoE³-366 ARGON FILLED

OTHER LOW-E OPTIONS: 240, 270, 5527

B-21 SERIES

CONSTANT FORCE BALANCE SYSTEM

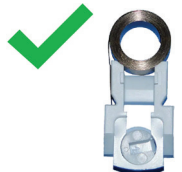

SMOOTH & EFFORTLESS OPERATION- Constant force balancers provide a steady & uniform force throughout the windows range of motion, resulting in smooth & effortless operation. This consistent performance ensures that opening & closing the windows is a hassle-free experience, offering convenience & comfort to homeowners.

MINIMAL MAINTENANCE- Constant force balancers are designed for long-term reliability with minimal maintenance requirements. Unlike traditional block & tackle balances that may require periodic adjustment or lubrication, constant force balancers operate flawlessly for extended periods without the need for maintenance.

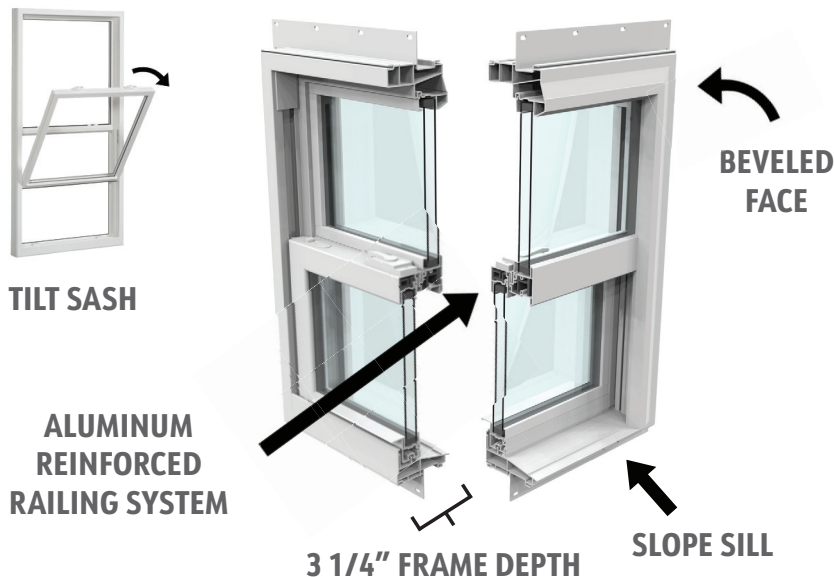

9600 SERIES

BLOCK & TACKLE



LIMITED LIFESPAN- Block & tackle balancers can wear out over time, especially if exposed to harsh weather conditions or frequent use. The cords or chains may fray, the pulleys can become worn, & the counterweights may lose their effectiveness leading to the need for constant replacement or repair.

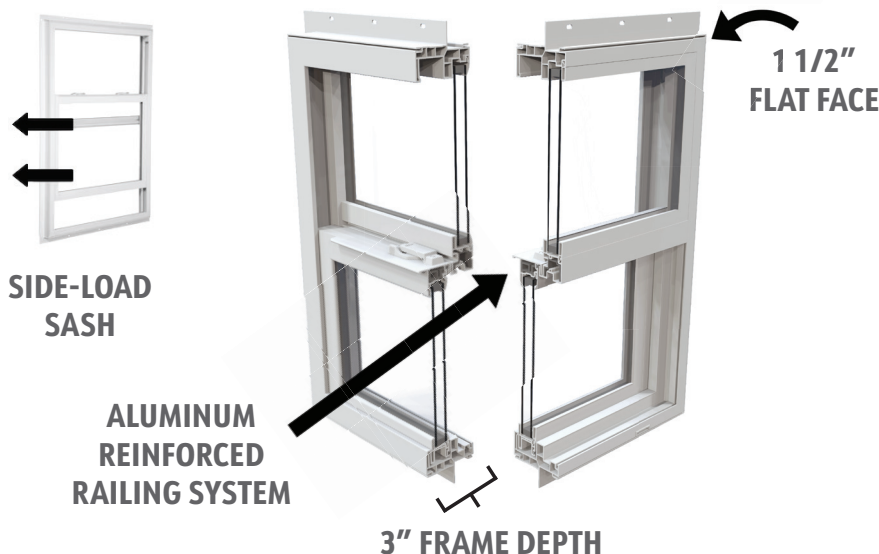

ARGON PERMEABILITY

Duraseal has one of the best argon resistant bond line adhesives to retain argon in your window longer and save more energy. This is vital to the window maintaining its thermal performance from day one to many years down the road. Argon gas is used as an insulating material in the airspace between panes of glass in vinyl windows. Since Argon is denser than air, sound waves encounter more resistance between the glass reducing the transmission of sound. While its primary function is to enhance thermal insulation by reducing heat transfer, it also contributes some soundproofing properties.

ENERGY EFFICIENCY

Crafted with precision, these windows provide excellent insulation, reducing energy costs & keeping your home comfortable year round.

Our windows are built to last featuring high quality materials ensuring longevity & resistance to the elements.



Warmest Edge = Best Performance



DECORATIVE GLASS



Obscure



Rain

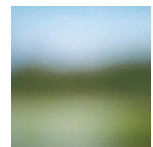

Satin

RATINGS

B21 SERIES	U-FACTOR	SHGC
SINGLE HUNG 1/1 J9549.05-116-46	.29	.22
SINGLE SLIDER 1X1 J9551.05-116-46	.29	.22
PICTURE WINDOW 1LT I9913.08-116-46	.27	.23

9600 SERIES	U-FACTOR	SHGC
SINGLE HUNG 1/1 K6156.03-116-45-R0	.28	.23
SINGLE SLIDER 1X1 K6158.03-116-45-R0	.29	.23
PICTURE WINDOW 1LT K6154.03-116-45-R0	.26	.25

B21 SERIES CALL SIZES

CALL SIZE WIDTH	SH/PW SINGLE UNIT	TWIN SH/PW	TRIPLE SH/PW	QUAD SH/PW
1-6	17 ½	35	52 ½	70
2-0	23 ½	47	70 ½	94
2-4	27 ½	55	82 ½	111 ½
2-6	29 ½	59	88 ½	119 ½
2-8	31 ½	63	94 ½	127 ½
3-0	35 ½	71	107 ½	143 ½
3-4	39 ½	79	119 ½	N/A
3-6	41 ½	83	125 ½	N/A
3-8	43 ½	87	131 ½	N/A
4-0	47 ½	95	143 ½	N/A

9600 SERIES CALL SIZES

CALL SIZE WIDTH	SH/PW SINGLE UNIT	TWIN SH/PW	TRIPLE SH/PW
1-6	17 ½	35 ½	52 ½
2-0	23 ½	47 ½	71 ½
2-4	27 ½	55 ½	83 ½
2-6	29 ½	59 ½	89 ½
2-8	31 ½	63 ½	95 ½
3-0	35 ½	71 ½	107 ½
3-4	39 ½	79 ½	119 ½
3-6	41 ½	83 ½	125 ½
3-8	43 ½	87 ½	131 ½
4-0	47 ½	95 ½	143 ½

GRID PATTERNS

5/8" (standard) & 3/4" internal muntin bars

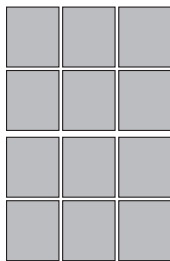

Colonial

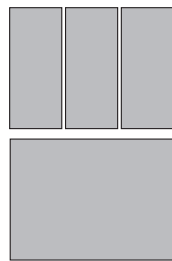

Three over one

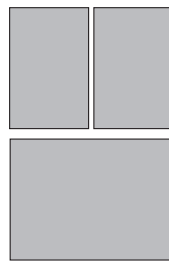

Two over one

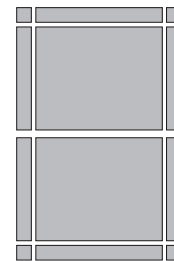

Prairie

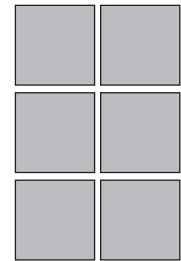

Customize to your liking

COLORS

VINYL

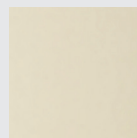

Almond

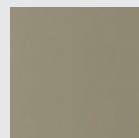

Clay

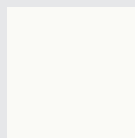

White

PAINTED

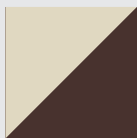

Almond Bronze

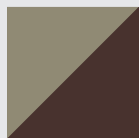

Clay Bronze

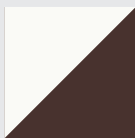

White Bronze

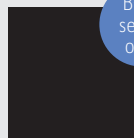

Black
Painted on both sides

B-21 series only

LAMINATE

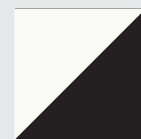

White
Black

SINGLE HUNG

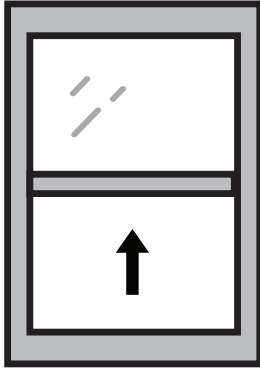

VERTICAL ELEGANCE- Our single hung windows boast a timeless vertical sliding design, adding a touch of sophistication to any room.

TILT-IN CLEANING- Experience hassle-free maintenance with the tilt-in feature allowing you to clean both sides of the glass from the comfort of your home (B21 Series).

EASY OPERATION- Enjoy effortless functionality with the operable bottom sash, allowing for smooth and controlled ventilation.

PICTURE WINDOW

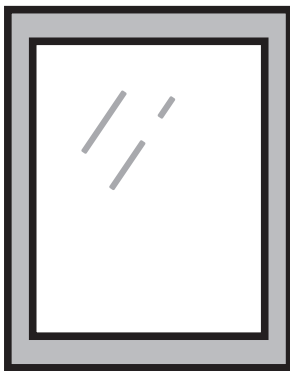

STATIONARY DESIGN- Fixed windows designed to be inoperable & cannot open or close. Their stationary nature makes them ideal for an unobstructed view.

ARCHITECTURAL APPEAL- Often used for achitectural design, fixed windows contribute to the overall aesthetic of a building. Available in various shapes & sizes for added style & visual interest.

NATURAL LIGHT- Fixed windows are excellent for maximizing natural light. The expansive glass allows sunlight to flood the interior, creating a bright & inviting atmopshere.

SCENIC VIEWS- Ideal for framing picturesque views. Fixed windows are commonly used in locations with stunning landscapes & scenery serving as a focal point, bringing the outdoors inside.

SLIDING WINDOW

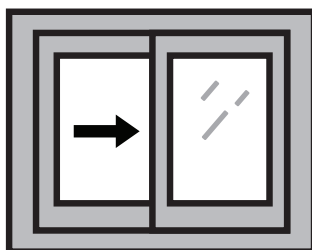

SMOOTH SLIDING ACTION- Experience effortless operation with our advanced sliding mechanism. Open & close windows with minimal force, enabling convenient ventilation & easy access to outdoor spaces.

Available in XO, OX, & XOX

CUSTOM STACKING

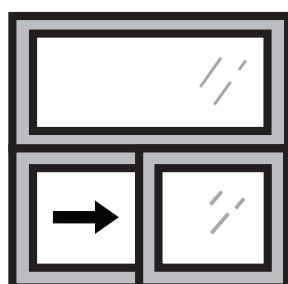

MULTI-WINDOW COMBINATIONS

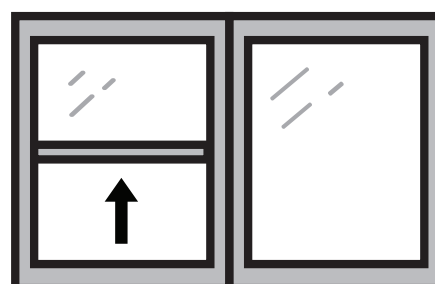

SPECIALTY SHAPES



DALLAS

11241 Leo Ln
Dallas, TX 75229

469.805.8098

info@buenavistawindows.net
quotes@buenavistawindows.net

AUSTIN

2700 W Pecan St #201
Pflugerville, TX 78660

737.742.8751

infoatx@buenavistawindows.net



www.buenavistawindows.net